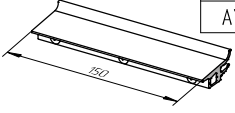
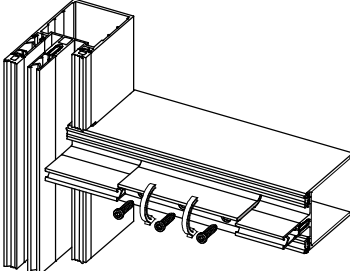
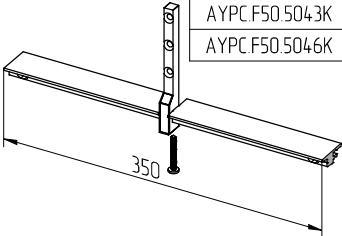
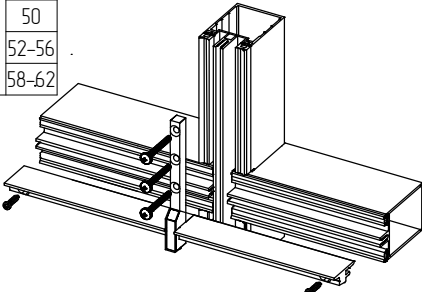
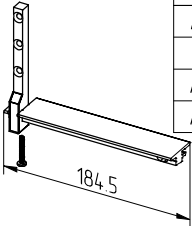
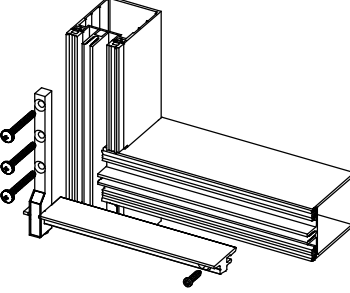
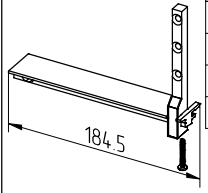
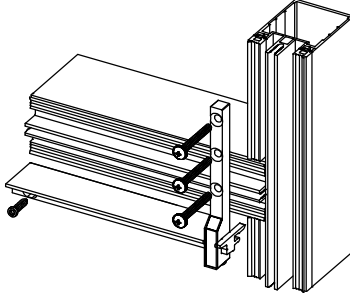

Наименование, артикул, эскиз	Цвет	Код по каталогу	Масса, кг	Кол-во в упаковке, шт	Масса упаковки друтто, кг	Исходный профиль	Применение																																																							
<p>Подкладка опорная</p> <table border="1"> <tr><td>AYPC.F50.5001</td><td>11327600</td><td>0.100</td><td>60</td><td>6.3</td><td>AYPC.F50.0838</td></tr> <tr><td>AYPC.F50.5002</td><td>11327700</td><td>0.108</td><td>52</td><td>6.1</td><td>AYPC.F50.0839</td></tr> <tr><td>AYPC.F50.5003</td><td>11327800</td><td>0.122</td><td>76</td><td>9.3</td><td>AYPC.F50.0840</td></tr> <tr><td>AYPC.F50.5004</td><td>11327900</td><td>0.137</td><td>26</td><td>3.6</td><td>AYPC.F50.0841</td></tr> <tr><td>AYPC.F50.5005</td><td>11328000</td><td>0.151</td><td>26</td><td>4.0</td><td>AYPC.F50.0842</td></tr> <tr><td>AYPC.F50.5006</td><td>11328100</td><td>0.165</td><td>26</td><td>4.30</td><td>AYPC.F50.0843</td></tr> </table>  <table border="1"> <tr><td>F50SG</td><td>F50SSG</td><td>F50HL</td><td>F50VL</td></tr> <tr><td>●</td><td>●</td><td>●</td><td>●</td></tr> </table> <p>единица измерения - шт.</p>	AYPC.F50.5001	11327600	0.100	60	6.3	AYPC.F50.0838	AYPC.F50.5002	11327700	0.108	52	6.1	AYPC.F50.0839	AYPC.F50.5003	11327800	0.122	76	9.3	AYPC.F50.0840	AYPC.F50.5004	11327900	0.137	26	3.6	AYPC.F50.0841	AYPC.F50.5005	11328000	0.151	26	4.0	AYPC.F50.0842	AYPC.F50.5006	11328100	0.165	26	4.30	AYPC.F50.0843	F50SG	F50SSG	F50HL	F50VL	●	●	●	●	00					<p>Применяется как опорная подкладка под стеклопакет</p> <table border="1"> <tr><td>Толщина заполнения, мм</td><td>32</td></tr> <tr><td></td><td>34-38</td></tr> <tr><td></td><td>40-44</td></tr> <tr><td></td><td>50</td></tr> <tr><td></td><td>52-56</td></tr> <tr><td></td><td>58-62</td></tr> </table> 	Толщина заполнения, мм	32		34-38		40-44		50		52-56		58-62
AYPC.F50.5001	11327600	0.100	60	6.3	AYPC.F50.0838																																																									
AYPC.F50.5002	11327700	0.108	52	6.1	AYPC.F50.0839																																																									
AYPC.F50.5003	11327800	0.122	76	9.3	AYPC.F50.0840																																																									
AYPC.F50.5004	11327900	0.137	26	3.6	AYPC.F50.0841																																																									
AYPC.F50.5005	11328000	0.151	26	4.0	AYPC.F50.0842																																																									
AYPC.F50.5006	11328100	0.165	26	4.30	AYPC.F50.0843																																																									
F50SG	F50SSG	F50HL	F50VL																																																											
●	●	●	●																																																											
Толщина заполнения, мм	32																																																													
	34-38																																																													
	40-44																																																													
	50																																																													
	52-56																																																													
	58-62																																																													
<p>Комплект подкладок опорных</p> <table border="1"> <tr><td>AYPC.F50.5031K</td><td>11363800</td><td>0.268</td><td>30</td><td>8.04</td></tr> <tr><td>AYPC.F50.5034K</td><td>11364100</td><td>0.358</td><td>30</td><td>10.74</td></tr> <tr><td>AYPC.F50.5037K</td><td>11364400</td><td>0.448</td><td>30</td><td>13.44</td></tr> <tr><td>AYPC.F50.5040K</td><td>11364700</td><td>0.538</td><td>28</td><td>15.06</td></tr> <tr><td>AYPC.F50.5043K</td><td>11365000</td><td>0.628</td><td>26</td><td>16.32</td></tr> <tr><td>AYPC.F50.5046K</td><td>11365300</td><td>0.717</td><td>24</td><td>17.21</td></tr> </table>  <table border="1"> <tr><td>F50SG</td><td>F50SSG</td><td>F50HL</td><td>F50VL</td></tr> <tr><td>●</td><td>●</td><td>●</td><td>●</td></tr> </table> <p>единица измерения - шт.</p>	AYPC.F50.5031K	11363800	0.268	30	8.04	AYPC.F50.5034K	11364100	0.358	30	10.74	AYPC.F50.5037K	11364400	0.448	30	13.44	AYPC.F50.5040K	11364700	0.538	28	15.06	AYPC.F50.5043K	11365000	0.628	26	16.32	AYPC.F50.5046K	11365300	0.717	24	17.21	F50SG	F50SSG	F50HL	F50VL	●	●	●	●	00					<p>Применяется как средняя опорная подкладка под тяжелые стеклопакеты</p> <table border="1"> <tr><td>Толщина заполнения, мм</td><td>32</td></tr> <tr><td></td><td>34-38</td></tr> <tr><td></td><td>40-44</td></tr> <tr><td></td><td>50</td></tr> <tr><td></td><td>52-56</td></tr> <tr><td></td><td>58-62</td></tr> </table>  <p>Комплект поставки: две алюминиевые детали, соединительный винт 4.8X32 DIN7981, заглушка из вспененного полиэтилена.</p>	Толщина заполнения, мм	32		34-38		40-44		50		52-56		58-62						
AYPC.F50.5031K	11363800	0.268	30	8.04																																																										
AYPC.F50.5034K	11364100	0.358	30	10.74																																																										
AYPC.F50.5037K	11364400	0.448	30	13.44																																																										
AYPC.F50.5040K	11364700	0.538	28	15.06																																																										
AYPC.F50.5043K	11365000	0.628	26	16.32																																																										
AYPC.F50.5046K	11365300	0.717	24	17.21																																																										
F50SG	F50SSG	F50HL	F50VL																																																											
●	●	●	●																																																											
Толщина заполнения, мм	32																																																													
	34-38																																																													
	40-44																																																													
	50																																																													
	52-56																																																													
	58-62																																																													
<p>Комплект подкладок опорных</p> <table border="1"> <tr><td>AYPC.F50.5032K</td><td>11363900</td><td>0.160</td><td>14</td><td>2.24</td></tr> <tr><td>AYPC.F50.5035K</td><td>11364200</td><td>0.216</td><td>14</td><td>3.02</td></tr> <tr><td>AYPC.F50.5038K</td><td>11364500</td><td>0.272</td><td>12</td><td>3.26</td></tr> <tr><td>AYPC.F50.5041K</td><td>11364800</td><td>0.328</td><td>10</td><td>3.28</td></tr> <tr><td>AYPC.F50.5044K</td><td>11365100</td><td>0.384</td><td>10</td><td>3.84</td></tr> <tr><td>AYPC.F50.5047K</td><td>11365400</td><td>0.439</td><td>8</td><td>3.51</td></tr> </table>  <table border="1"> <tr><td>F50SG</td><td>F50SSG</td><td>F50HL</td><td>F50VL</td></tr> <tr><td>●</td><td>●</td><td>●</td><td>●</td></tr> </table> <p>единица измерения - шт.</p>	AYPC.F50.5032K	11363900	0.160	14	2.24	AYPC.F50.5035K	11364200	0.216	14	3.02	AYPC.F50.5038K	11364500	0.272	12	3.26	AYPC.F50.5041K	11364800	0.328	10	3.28	AYPC.F50.5044K	11365100	0.384	10	3.84	AYPC.F50.5047K	11365400	0.439	8	3.51	F50SG	F50SSG	F50HL	F50VL	●	●	●	●	00					<p>Применяется как левая опорная подкладка под тяжелые стеклопакеты</p> <table border="1"> <tr><td>Толщина заполнения, мм</td><td>32</td></tr> <tr><td></td><td>34-38</td></tr> <tr><td></td><td>40-44</td></tr> <tr><td></td><td>50</td></tr> <tr><td></td><td>52-56</td></tr> <tr><td></td><td>58-62</td></tr> </table>  <p>Комплект поставки: две алюминиевые детали, соединительный винт 4.8X32 DIN7981, заглушка из вспененного полиэтилена.</p>	Толщина заполнения, мм	32		34-38		40-44		50		52-56		58-62						
AYPC.F50.5032K	11363900	0.160	14	2.24																																																										
AYPC.F50.5035K	11364200	0.216	14	3.02																																																										
AYPC.F50.5038K	11364500	0.272	12	3.26																																																										
AYPC.F50.5041K	11364800	0.328	10	3.28																																																										
AYPC.F50.5044K	11365100	0.384	10	3.84																																																										
AYPC.F50.5047K	11365400	0.439	8	3.51																																																										
F50SG	F50SSG	F50HL	F50VL																																																											
●	●	●	●																																																											
Толщина заполнения, мм	32																																																													
	34-38																																																													
	40-44																																																													
	50																																																													
	52-56																																																													
	58-62																																																													
<p>Комплект подкладок опорных</p> <table border="1"> <tr><td>AYPC.F50.5033K</td><td>11364000</td><td>0.160</td><td>14</td><td>2.24</td></tr> <tr><td>AYPC.F50.5036K</td><td>11364300</td><td>0.216</td><td>14</td><td>3.02</td></tr> <tr><td>AYPC.F50.5039K</td><td>11364600</td><td>0.272</td><td>12</td><td>3.26</td></tr> <tr><td>AYPC.F50.5042K</td><td>11364900</td><td>0.328</td><td>10</td><td>3.28</td></tr> <tr><td>AYPC.F50.5045K</td><td>11365200</td><td>0.384</td><td>10</td><td>3.84</td></tr> <tr><td>AYPC.F50.5048K</td><td>11365500</td><td>0.439</td><td>8</td><td>3.51</td></tr> </table>  <table border="1"> <tr><td>F50SG</td><td>F50SSG</td><td>F50HL</td><td>F50VL</td></tr> <tr><td>●</td><td>●</td><td>●</td><td>●</td></tr> </table> <p>единица измерения - шт.</p>	AYPC.F50.5033K	11364000	0.160	14	2.24	AYPC.F50.5036K	11364300	0.216	14	3.02	AYPC.F50.5039K	11364600	0.272	12	3.26	AYPC.F50.5042K	11364900	0.328	10	3.28	AYPC.F50.5045K	11365200	0.384	10	3.84	AYPC.F50.5048K	11365500	0.439	8	3.51	F50SG	F50SSG	F50HL	F50VL	●	●	●	●	00					<p>Применяется как правая опорная подкладка под тяжелые стеклопакеты</p> <table border="1"> <tr><td>Толщина заполнения, мм</td><td>32</td></tr> <tr><td></td><td>34-38</td></tr> <tr><td></td><td>40-44</td></tr> <tr><td></td><td>50</td></tr> <tr><td></td><td>52-56</td></tr> <tr><td></td><td>58-62</td></tr> </table>  <p>Комплект поставки: две алюминиевые детали, соединительный винт 4.8X32 DIN7981, заглушка из вспененного полиэтилена.</p>	Толщина заполнения, мм	32		34-38		40-44		50		52-56		58-62						
AYPC.F50.5033K	11364000	0.160	14	2.24																																																										
AYPC.F50.5036K	11364300	0.216	14	3.02																																																										
AYPC.F50.5039K	11364600	0.272	12	3.26																																																										
AYPC.F50.5042K	11364900	0.328	10	3.28																																																										
AYPC.F50.5045K	11365200	0.384	10	3.84																																																										
AYPC.F50.5048K	11365500	0.439	8	3.51																																																										
F50SG	F50SSG	F50HL	F50VL																																																											
●	●	●	●																																																											
Толщина заполнения, мм	32																																																													
	34-38																																																													
	40-44																																																													
	50																																																													
	52-56																																																													
	58-62																																																													